

3-POINT BALE FORKS AND BALE TINES

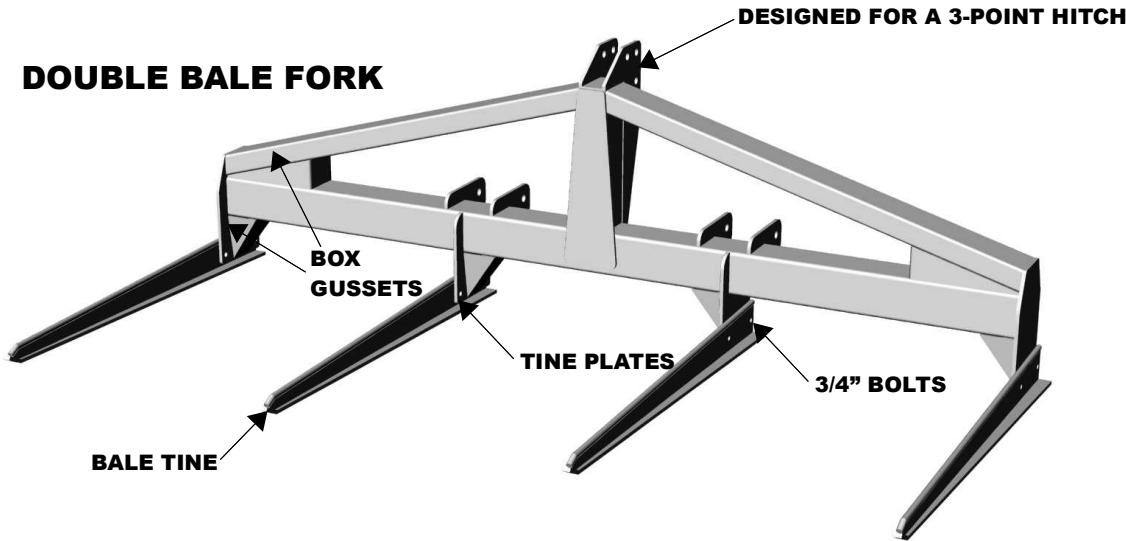

DOUBLE BALE FORK

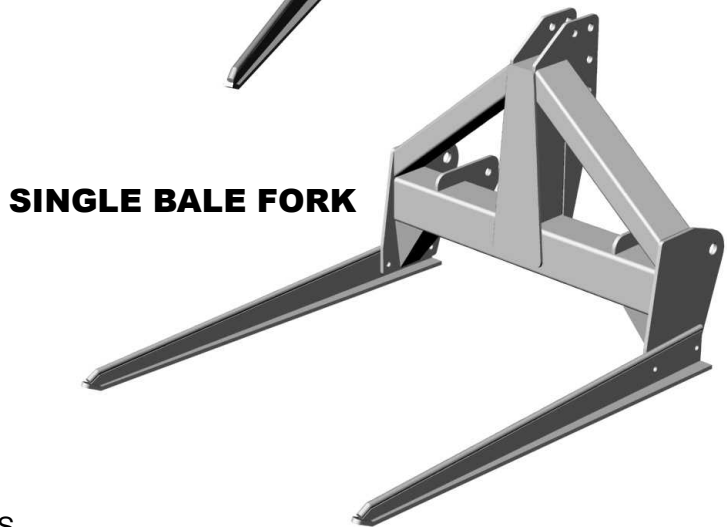

SINGLE BALE FORK

3-POINT BALE FORK

MATERIALS

- LOWER TUBE – 6X6X1/4” SQUARE TUBE
- TOP TUBES – 6X3X1/4” RECTANGLE TUBE
- VERTICAL TUBE – 6X4X1/4” RECTANGLE TUBE
- PIN MOUNTING PLATES – 1/2” A36 PLATE
- TINE PLATES – 1/2” A36 PLATE
- BOX GUSSETS – 1/4” A36 PLATE
- BOLTS – 3/4” X 2” BOLTS WITH NUTS AND WASHERS

OUR 3-POINT BALE FORK IS MADE FROM HEAVY WALL TUBING, 1/2” PLATE, AND 1/4” PLATE. ALL PLATES ARE CNC PLASMA CUT TO ENSURE PART QUALITY. THE BALE FORK IS OF “ALL WELDED CONSTRUCTION” AND FEATURES MULTIPLE TOP PIN LOCATIONS ALONG WITH LOWER STEP PIN MOUNTS FOR A UNIVERSAL FIT. BOX GUSSETS ARE USED AT ALL TUBE JOINTS AS WELL AS ON THE TINE MOUNTS ENSURING MAXIMUM DURABILITY.

BALE TINE

MATERIALS

- “SKID” BOTTOM PLATE - 1/2” PLATE PLASMA CUT FORMED AT THE TIP
- VERTICAL PLATE – 1/2” PLATE PLASMA CUT W/ HOLES FOR 3/4” BOLTS (BOLT PATTERN IS 3/4” BOLTS ON 8” CENTERS)
- WEAR ROD – 3/4” DIAMETER HOT ROLLED ROUND BAR

OUR BALE TINES ARE MADE FROM QUALITY MATERIALS AND WELDED TOGETHER TO ENSURE LONG LIFE. WE INCLUDE THESE TINES WITH OUR BALE FORK SHOWN ABOVE.

